

PMG 10PV	
Power [kW]	10
Speed [rpm]	60
Voltage [V]	220
Short Circuit Current [A]	84
THD	4.9
Power factor	0.91
Weight [kg]	45
Efficiency [100% load]	95.6
Efficiency [75% load]	95
Efficiency [50% load]	94.4
Efficiency [25% load]	93.7
Protection class	IP54
Insulation class	F
Thermal class	B
Torque [N.m]	84
Cooling	Air-to-liquid

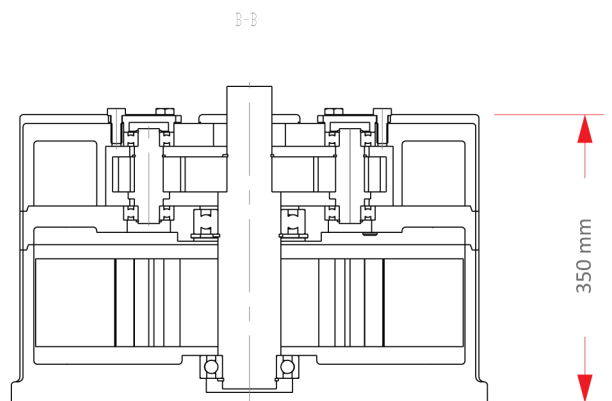
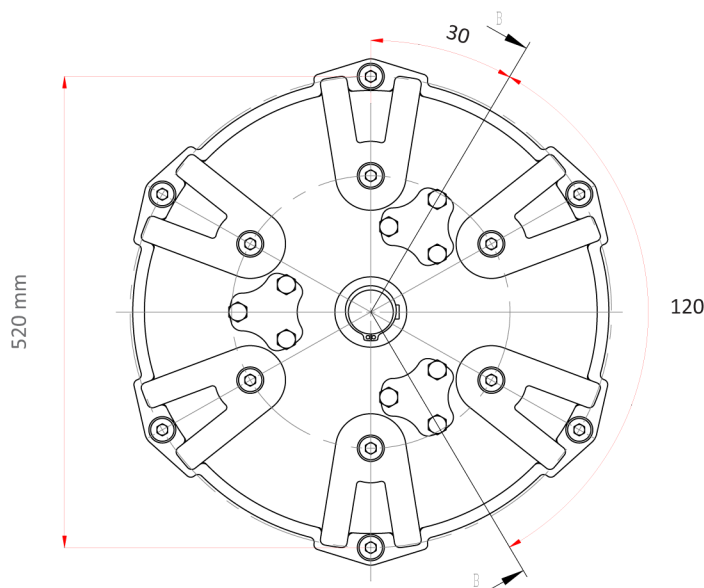
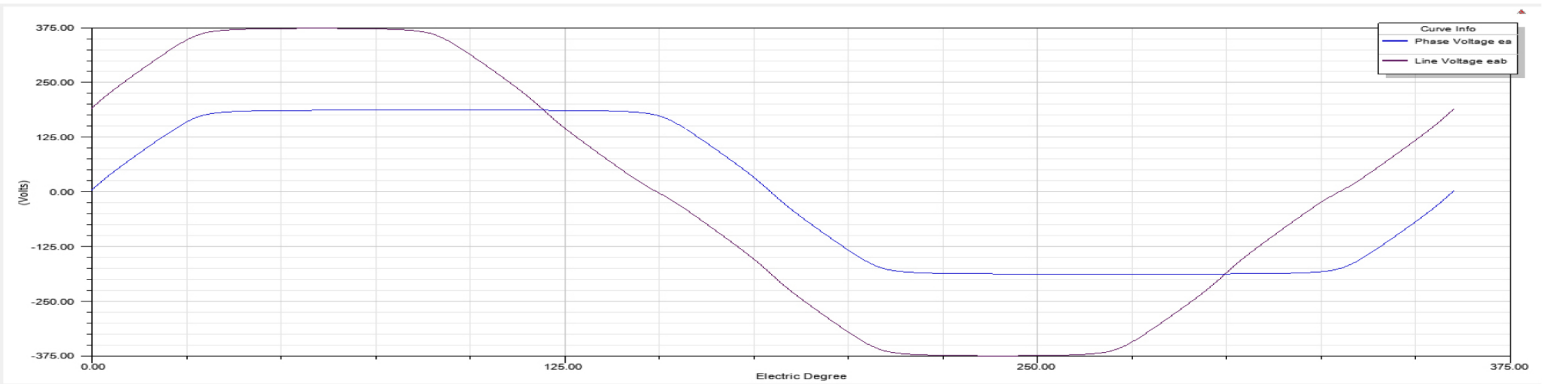
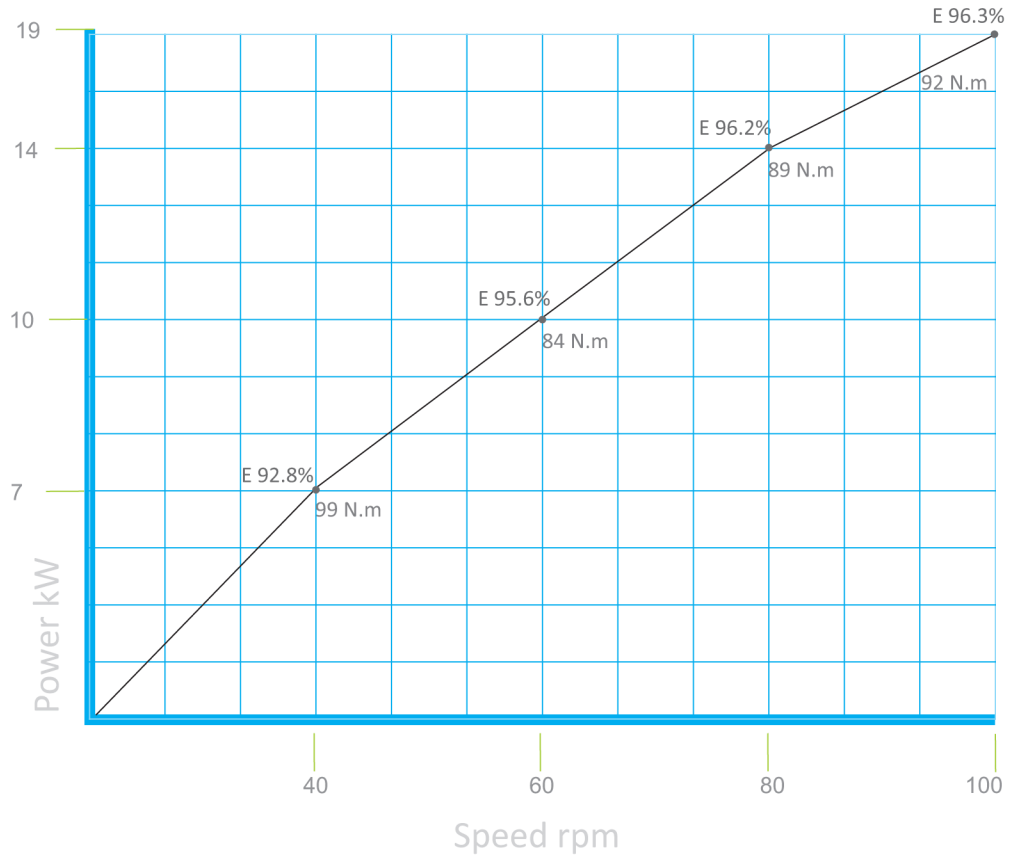

PMG 10PV