

	PMG 800PH
Power [kW]	800
Speed [rpm]	60
Voltage [V]	400
Short Circuit Current [A]	3700
THD	2.9
Power factor	0.93
Weight [kg]	468
Efficiency [100% load]	98.2
Efficiency [75% load]	97.6
Efficiency [50% load]	96.8
Efficiency [25% load]	96
Protection class	IP54
Insulation class	F
Thermal class	B
Torque [N.m]	6640
Cooling	Air-to-liquid

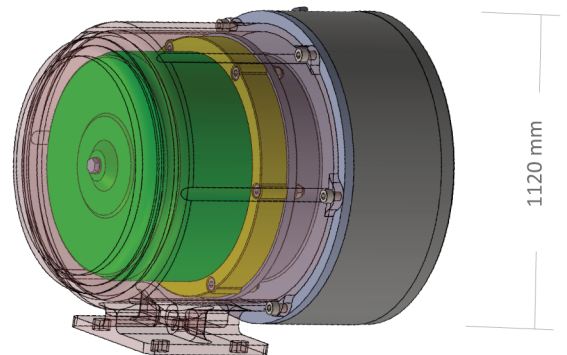
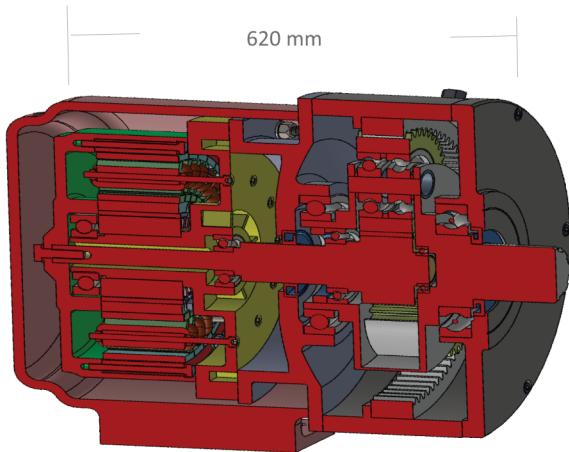
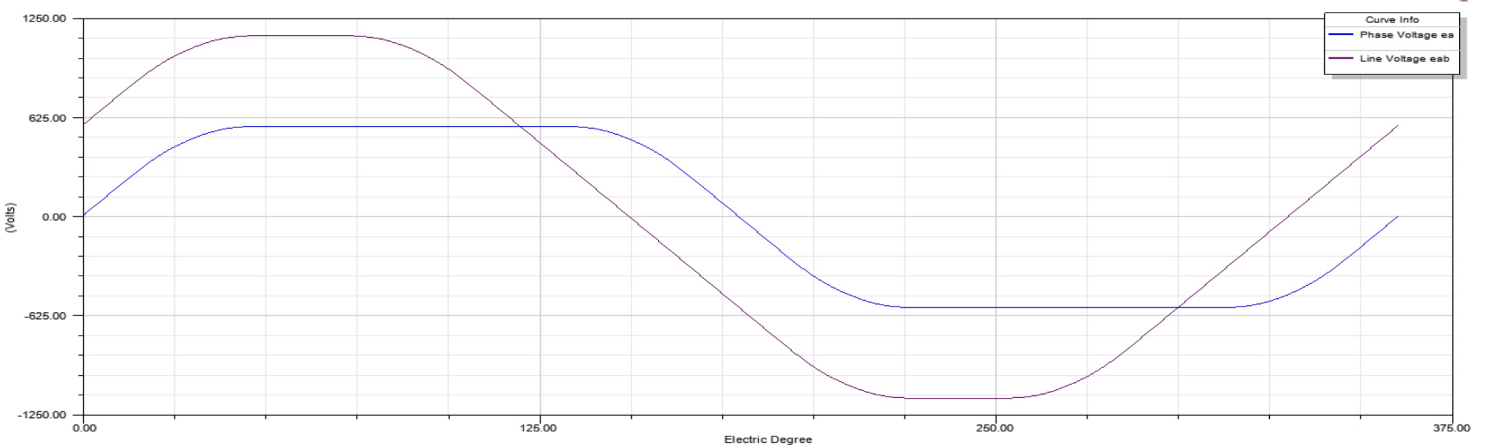
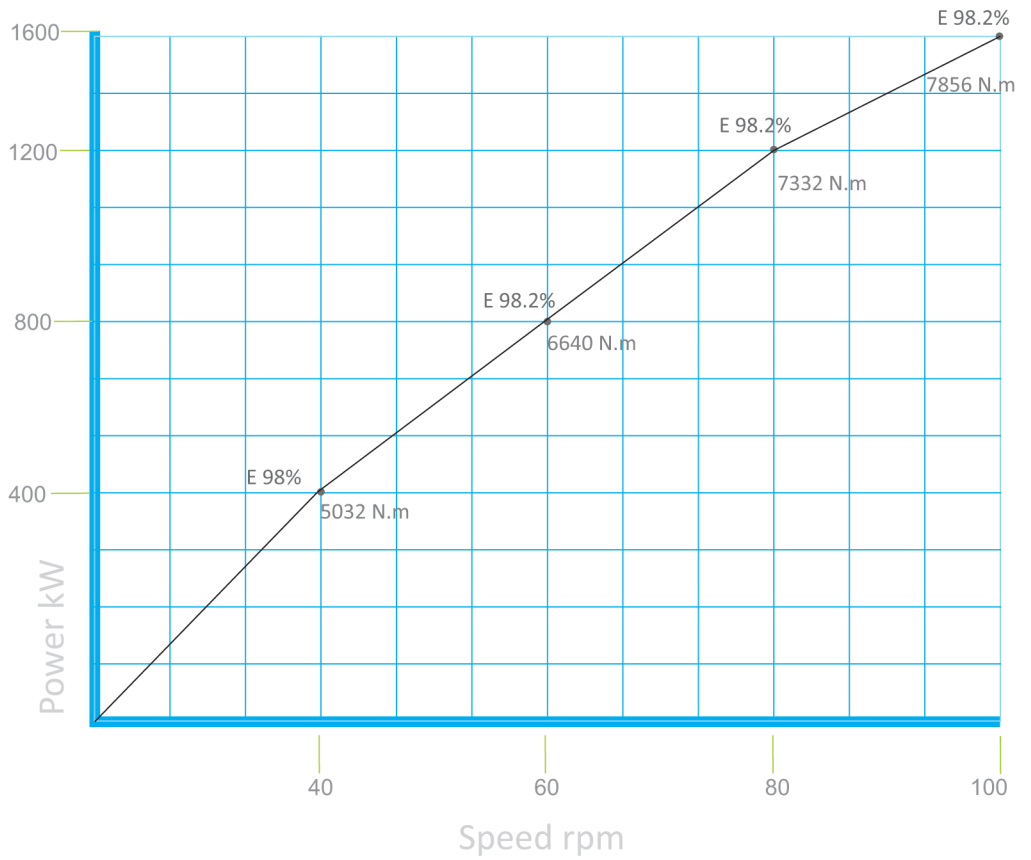

PMG 800PH